



TECHNICAL MANUAL FOR DVC-340 CAMERAS

Manual Number: 86-0340-01
Release Date: August 24, 2006



1.	INTRODUCTION	4
2.	RECEIVING AND UNPACKING.....	5
3.	EQUIPMENT SUPPLIED.....	5
3.1.	IMPORTANT INFORMATION REGARDING THE POWER SUPPLY	5
3.2.	OPTIONAL ITEMS	5
4.	INSTALLATION	5
4.1.	HOST COMPUTER REQUIREMENTS.....	5
4.1.1.	<i>Operating system:</i>	5
4.1.2.	<i>Hardware, CameraLink configuration:</i>	6
4.1.3.	<i>Hardware, Gigabit Ethernet configuration:</i>	6
4.2.	INSTALLING THE GIGABIT ETHERNET OR CAMERA LINK HOST INTERFACE BOARD.....	6
4.3.	INSTALLING THE SOFTWARE.....	6
4.4.	INSTALLING THE CAMERA HARDWARE	6
5.	CAMERA FUNCTIONS.....	6
5.1.	OPERATING SPEED.....	7
5.1.1.	<i>20 MHz operation</i>	7
5.1.2.	<i>40 MHz operation</i>	7
5.2.	OPERATIONAL MODES.....	7
5.2.1.	<i>Continuous, overlapped exposure mode with electronic shuttering</i>	7
5.2.2.	<i>Continuous, overlapped, extended-exposure mode</i>	8
5.2.3.	<i>Continuous, non-overlapped exposure mode</i>	8
5.2.4.	<i>Edge-triggered exposure (single frame capture) mode</i>	8
5.2.5.	<i>Bulb (pulse-width exposure) mode</i>	9
5.3.	BINNING	9
5.4.	REGION OF INTEREST	10
6.	CCD PHENOMENA	10
6.1.	BLOOMING	10
6.2.	SMEAR.....	10
7.	MAINTENANCE	11
	IMPORTANT WARRANTY INFORMATION	11
7.1.	CLEANING GUIDELINES.....	11
7.1.1.	<i>Cleaning the lens or optical assembly</i>	11
7.1.2.	<i>Standard (non-cooled) camera precautions</i>	11
7.1.3.	<i>Cleaning the infra-red filter</i>	11
7.1.4.	<i>Infra-red filter removal and installation</i>	13
7.1.5.	<i>How to remove the IR filter</i>	13
7.1.6.	<i>Cleaning the CCD faceplate</i>	15
8.	WARRANTY AND AFTER-SALE SERVICE	16
9.	COPYRIGHT INFORMATION.....	16
	APPENDIX A: EXPOSURE TIMING DIAGRAMS.....	18

APPENDIX B: DESCRIPTION OF DVC-340 AUXILIARY AND POWER SUPPLY CONNECTORS.....23

AUXILIARY CONNECTOR.....23

Auxiliary Connector Pin Signal list:.....23

Pin 1, ENL.....23

Pin 2, DIFF_RESET_OUT.....23

Pin 3, TTL_RESET.....24

Pin 4, GND.....24

Pin 5, ENF.....24

Pin 6, STROBE (and programmable output).....24

POWER SUPPLY CONNECTOR PIN ASSIGNMENTS24

APPENDIX C: SPECIFICATIONS25

1. Introduction

DVC Company, based in Austin, Texas, is a leading manufacturer of high-performance digital cameras. We thank you for purchasing from the DVC-340 product line.

The DVC-340 cameras are based on the Kodak KAI-0340 interline CCD, which provides 640(H) x 480 (V) pixel resolution and 7.4 μm square pixels with high quantum efficiency and low noise. The DVC-340 is available with either Gigabit Ethernet or CameraLink digital video and control interface.

Additionally, the DVC-340 is bundled with the full complement of DVC software.

For end-users, the DVCView imaging application provides full control of up to 8 cameras simultaneously through an intuitive user interface, and it enables the user to acquire, pan, zoom, analyze, and save imagery and metadata. Additionally, DVCView provides direct-to-disk video streaming, time-lapse capture, image averaging, image background subtraction, and flat-fielding.

For developers, DVC also offers a software developer's kit, which includes a comprehensive API to streamline the integration of any DVC camera into your system. After software installation, the SDK can be found in the /dvcco/docs directory.

This manual is a functional overview of the camera, and it is meant to be a companion to the DVCView User Manual and the SDK.

Thank you again from all of us at DVC!

2. Receiving and Unpacking

Your DVC-340 camera was thoroughly tested and carefully packed at the factory. Once the camera shipment is accepted for delivery, the carrier assumes full responsibility for its safe arrival. Should you receive your shipment with any damage—concealed or apparent—please contact the carrier at once. The carrier will instruct you on how to initiate a damage claim. If a visual inspection reveals damage upon receipt, it must be noted on the freight bill or express receipt and the notation signed by the carrier's agent. Failure to do so can result in the carrier refusing to honor the claim.

To return your camera to DVC for service, you must first contact the DVC Customer Service Department in the United States at 512-301-9564 and request a Return Material Authorization (RMA). Returns will not be accepted without an RMA. See Section 8 for details.

3. Equipment Supplied

The following is a list of standard equipment supplied with the DVC-340 camera:

- DVC-340 camera
- CameraLink or Gigabit Ethernet interface board
- CameraLink or Gigabit Ethernet cable
- Regulated power supply
- Line cord with plug for country of service
- DVC software CD

3.1. Important information regarding the power supply

The DVC-340 power supply can be configured for 115VAC or 220VAC mains voltages via the selection switch on the underside of the unit. Before connecting to the mains, please verify that the switch is in the proper position for your location. **Failure to set the power supply switch to the proper mains voltage may result in damage to the camera, the power supply, or both. Such damage is not covered under warranty.**

NOTE: Dangerous voltage exists within the power supply. Do not tamper with or open the supply under any circumstances. Doing so may expose lethal voltage to personnel and will void the warranty.

3.2. Optional items

The following items may be ordered from authorized DVC dealers and are *not* typically supplied with the camera:

- Lenses or other optical elements
- Third-party image analysis software

4. Installation

4.1. Host computer requirements

4.1.1. Operating system:

Windows XP or Windows 2000

4.1.2. Hardware, CameraLink configuration:

At least a 500MHz Pentium III processor, 256 MB RAM, 100MB of free hard drive space, and an available slot for the CameraLink interface board. For optimal performance, the recommended hardware configuration is a 2 GHz or greater P4 with 128 MB or RAM and a graphics card with at least 32 MB of video ram and OpenGL(tm) hardware support.

4.1.3. Hardware, Gigabit Ethernet configuration:

At least a 2 GHz Pentium 4 processor, 512 MB RAM, 100MB of free hard drive space, an available slot for the Gigabit Ethernet interface board, and a graphics card with at least 32 MB of video ram and OpenGL(tm) hardware support.

4.2. Installing the Gigabit Ethernet or CameraLink host interface board

Follow the instructions included with the CameraLink board

This PCI interface board contains sensitive electronic devices that can be damaged by static discharge. Use appropriate static control methods when removing the board from the antistatic shipping bag and when installing it into the host computer.

4.3. Installing the Software

Place DVC Software installation CD in the CD or DVD drive. The installer will launch automatically and guide each installation step.

4.4. Installing the camera hardware

This camera contains sensitive electronic devices that can be damaged by static discharge. Use appropriate static control methods when handling the camera. Avoid contact with connector pins when cables and plugs are removed.

- Mount the camera in the desired location
IMPORTANT: To avoid dust accumulation on the CCD sensor, do not remove the protective lens mount cap until ready to mount the camera to the optical system. The cap should be replaced whenever the camera is removed from the optical system
- Connect the 9-pin power supply connector to the back of the camera and secure it with the thumbscrews, finger-tight
- Connect the camera to the host with the supplied CameraLink cable and secure it at both ends with the thumbscrews, finger-tight
- Connect the power supply line cord to the mains
- Switch the power supply on

5. Camera Functions

The DVC-340 is a versatile, high-performance digital video camera with functions tailored to scientific and industrial markets. It is capable of both high-speed readout (40 MHz pixel rate) and low-noise readout (20 MHz pixel rate), both at 12 bits.

The DVC-340 has five basic operating modes described in detail below. Each mode can be operated at either 20 or 40 MHz and can support binning and region of interest.

All operational modes are initiated by a trigger signal. In the continuous modes, the trigger initiates the stream and the camera continues to run in streaming mode until disabled by the host computer. The edge-triggered, single-frame mode produces one exposure in response to the leading (falling) edge of the trigger signal and then returns to an armed state, awaiting the next trigger. Finally, in bulb mode, the camera exposes for the duration of the trigger pulse, beginning on the leading (falling) edge and ending on the trailing edge. Readout occurs immediately after the trailing edge and then the camera returns to an armed state, awaiting the next pulse.

The trigger signal can have three different sources: the external, TTL trigger via the auxiliary connector (see appendix B), the software-controlled trigger via a hard-wired CameraLink camera control line, or the software-controlled through camera trigger command, via the CameraLink serial port. Developers should consult the DVC Camera API documentation for further information on the software-controlled triggers.

If the TTL, external trigger is used, the trigger signal must be active-low. The trigger point is the high-to-low (leading edge) of the trigger signal.

5.1. Operating speed

The DVC-340 is capable of operating at pixel rates of 20MHz and 40MHz. All camera functions (e.g. exposure mode, binning, ROI, etc.) are operational at either speed, subject to the limitations below.

5.1.1. 20 MHz operation

20MHz operation gives the user the maximum dynamic range and minimum noise floor. Dynamic range refers to the maximum signal swing under which the camera meets performance specifications, and it is expressed in the maximum number of captured electrons on the CCD. At 20MHz, the DVC-340 is capable of approximately 38,000 electrons dynamic range.

5.1.2. 40 MHz operation

40MHz operating speed provides the user with the highest capture frame rates at the expense of slightly higher noise and heat generation and lower dynamic range. Because of amplifier limitations on the KAI-0340 CCD, the DVC-340 is capable of approximately 20,000 electrons dynamic range at 40 MHz.

5.2. Operational modes

The following section describes the distinct operating modes of the DVC-340 cameras. Users of DVCView software will find many of these modes seamlessly integrated to make operation of the camera as easy as possible. However, developers have full control of these modes via the DVC camera API.

Refer to **Appendix A** for exposure timing diagrams.

5.2.1. Continuous, overlapped exposure mode with electronic shuttering

This mode operates the CCD in a “video” mode, in which the previous exposure is being read out while the current exposure is underway. Once initiated via trigger, the camera operates continuously in this fashion until halted by the host computer.

Exposure is controlled using “electronic shuttering.” Depending on the user’s exposure setting, electronic shuttering inhibits the CCD exposure during a specific portion of the readout interval. Referring to the first figure in appendix A, the shorter the desired exposure, the longer the inhibition of exposure during the readout of the previous frame. Regardless of exposure time, frame rate remains constant. The maximum exposure time in this mode is the time required to read out one frame, and that frame time depends on the pixel rate, ROI, and binning settings.

Exposure range (full-resolution—no binning or ROI):

20MHz Readout: Increments of 36 microseconds, ranging from 36 microseconds to 17.3 milliseconds.

40MHz Readout: Increments of 18 microseconds, ranging from 18 microseconds to 8.8 milliseconds.

5.2.2. Continuous, overlapped, extended-exposure mode

In this mode, exposure and readout are overlapped, but the exposure ranges from one frame-time (time taken to read out entire frame) to many seconds. This mode is typically used if intermediate exposure times are desired but with the fastest frame rate possible. Once initiated via trigger, the camera operates continuously in this fashion until it is halted by the host computer.

Exposure range (full-resolution—no binning or ROI):

20MHz Readout: Increments of 36 microseconds, ranging from 17.3 milliseconds to 2400 seconds.

40MHz Readout: Increments of 18 microseconds, ranging from 8.8 milliseconds to 1200 seconds.

5.2.3. Continuous, non-overlapped exposure mode

In this mode, the camera alternately exposes and reads out the CCD in a streaming fashion, without any overlap. This mode allows a wider range of exposures within the mode, though frame rate decreases with increasing exposure time. Once initiated via trigger, the CCD operates continuously in this fashion until the camera is stopped.

Exposure range (full-resolution—no binning or ROI):

20MHz Readout: Increments of 36 microseconds, ranging from 36 microseconds to 2400 seconds.

40MHz Readout: Increments of 18 microseconds, ranging from 18 microseconds to 1200 seconds.

5.2.4. Edge-triggered exposure (single frame capture) mode

Edge-triggered exposure mode enables the camera to initiate an exposure immediately upon the leading (falling) edge of the external or CameraLink control lines, with an exposure time set by software. Alternatively, the exposure can be initiated by the host via the DVC API. The exposure and readout sequence is the same as the non-

overlapped, continuous mode and has the same exposure range, except only one frame is generated. Once the readout of that frame has finished, the camera returns to the armed state, awaiting the next trigger edge.

If subsequent trigger pulses occur faster than the combined exposure and readout time, any trigger received during the exposure or readout time will be ignored, as illustrated in appendix A.

Exposure range (full-resolution—no binning or ROI):

20MHz Readout: Increments of 36 microseconds, ranging from 36 microseconds to 2400 seconds.

40MHz Readout: Increments of 18 microseconds, ranging from 18 microseconds to 1200 seconds.

5.2.5. Bulb (pulse-width exposure) mode

The term “bulb” mode is borrowed from photography, denoting a camera setting in which the shutter stays open as long as the shutter button is depressed. Bulb mode in the DVC-340 is analogous in that the CCD exposes as long as the trigger signal is asserted (a low logic level on the external trigger or a low command on the CameraLink CC1 control line). Upon the rising edge of the trigger signal, readout of the exposure is initiated. Maximum exposure time is indefinite, although dark current will set the practical exposure time limit, depending on the operating temperature and the tolerance of the application to dark current pattern noise.

Exposure range:

20MHz or 40MHz Readout: 10us minimum. Maximum limited by dark current and particular application.

5.3. Binning

Binning is the process of summing adjacent lines and/or pixels in order to increase dynamic range, sensitivity, or both. Binning can either be accomplished on the CCD itself by summing the collected charge (on-chip binning) or in software, after A/D conversion. On-chip binning can result in slightly lower noise relative to software binning, under certain circumstances. Because fewer lines are actually read out when binning vertically, on-chip binning in the vertical direction can produce a significant increase in frame rate with increasing binning ratios. However, because the clocking cannot be accelerated in the horizontal direction, horizontal binning provides no such speed increase.

In all modes of operation, the DVC-340 is capable of arbitrary on-chip binning (2x, 3x, 4x, 5x...21x,...) in the vertical direction, and 2x, 3x, and 4x on-chip binning in the horizontal direction. As vertical binning increases, antiblooming control decreases, so the user must control image illumination more carefully while binning. However, blooming does not cause any damage to the camera.

As binning factor increases, the CCD vertical registers are driven faster. This naturally causes more heating of the CCD and driving electronics. Since dark current generation increases with CCD die temperature, a noticeable increase in CCD dark current can occur at very high binning factors.

5.4. Region of Interest

Arbitrary, on-chip vertical Region of Interest (ROI) is fully supported on the DVC-340 cameras. As illustrated below, when ROI is enabled, the regions above and below the region of interest are “dumped” as fast as the CCD allows. The region of interest itself is read out normally. Dumping unwanted lines outside the ROI can significantly increase the readout rate of the camera. DVCView software provides interactive, graphical ROI selection, and the DVC camera API provides developers with full ROI control. On-chip horizontal ROI is not available. Simultaneous binning and ROI is fully supported.

As in binning, the CCD vertical registers are driven faster when the region of interest is reduced. Dark current can increase during operation with small regions of interest.

6. CCD phenomena

The KAI-0340 CCD is a high-performance image sensor with remarkably ideal behavior over a wide operating range. To be as versatile as possible, the DVC-340 camera exploits as much of the CCD capability as possible and provides the user a great degree of control over the CCD functions. As a result, it is possible to observe some interesting, low-level CCD phenomena under certain extreme conditions.

6.1. Blooming

Blooming is the result of charge spillover in the vertical transfer regions when the signal greatly exceeds saturation. The DVC-340 provides anti-blooming control, which suppresses blooming under most imaging conditions. If signal levels are extreme and such high signal levels cover a large percentage of the field of view, blooming may occur. The result is jagged, vertical bright streaks running below such regions.

During binning, it is possible to bloom in the horizontal direction, especially when binning greater than 4x vertically. This is because the horizontal register charge capacity is exceeded, the KAI-0340 horizontal register has no anti-blooming capability and charge spills over during horizontal readout. Therefore, illumination levels must be more carefully controlled as the vertical binning factor is increased.

6.2. Smear

Smear is inherent to interline CCD sensors such as the KAI-0340. It is the result of transferring image charge out of the pixels and into the adjacent vertical charge-transfer registers while photons strike the CCD. Though the vertical charge-transfer registers are covered with a light shield, unwanted signal can be introduced into them either by small amounts of light leaking under the light shield or by signal electrons diffusing into the transfer region from the adjacent pixels.

Smear is typically noticed during very short exposure times, when an extremely high light intensity is incident on the CCD. The result is regions of elevated signal level extending above and below very bright regions. Kodak interline CCDs exhibit very low smear levels, and smear should not be noticeable under normal operating conditions.

7. Maintenance

IMPORTANT WARRANTY INFORMATION

There are no user serviceable parts inside the camera. Removing the rear cover of the camera without express authorization from DVC Company will void the camera warranty.

DVC professional cameras are manufactured in a clean environment. Before shipping, each camera is tested to assure that it meets stringent specifications for cleanliness and quality.

7.1. Cleaning Guidelines

Frequent lens changes, especially without careful attention to contaminants, can allow debris to accumulate on the infra-red blocking filter and lens surfaces. Therefore, DVC Company provides the following guidelines for cleaning those components.

To minimize the need to clean the optical surfaces, do not remove the protective lens mount cap shipped with the DVC-340 camera until you are ready to mount the camera to the optical system.

7.1.1. Cleaning the lens or optical assembly

Please follow the lens manufacturer's recommendations for cleaning. DVC Company is not responsible for any damage caused to a lens or optical assembly caused by customer cleaning or misuse.

To ensure optimum image quality with any DVC camera, do not remove the protective lens-mount cap until ready to mount the camera on the application. If the camera is removed from the application, immediately replace the cap. Doing so will keep dust and other contaminants from accumulating on the optical surfaces. In addition, please note the following model-specific guidelines.

7.1.2. Standard (non-cooled) camera precautions

While the lens mounting ring and locking flange allow the user some lens back-focus adjustment, complete removal of the ring will expose the CCD faceplate and will likely cause debris to accumulate on its surface. **Extreme care should be taken to avoid completely removing the lens mounting ring and exposing the CCD faceplate unless absolutely necessary. Fingerprints or other evidence of contact with the CCD faceplate may void the warranty.**

7.1.3. Cleaning the infra-red filter

The infra-red filter is visible when the lens is removed, mounted inside the lens mounting ring. This filter blocks invisible, near-infra-red light from reaching the CCD sensor. This is desirable in most applications where the camera is imaging in the visible spectrum.

7.1.3.1. What must I do before cleaning the infra-red filter?

Do not remove the filter from the camera.

First, remove the lens and carefully examine the filter in a clean location under a strong, direct light. Try to determine if the contaminants are a few dust particles, oily smudge (such as fingerprints) or both.

7.1.3.2. What if the contamination is only a few dust particles?

Use a CLEAN, DRY (preferably brand-new), camel hair lens cleaning brush (such as those used by photographers) to gently wipe the particles off of the filter.

7.1.3.3. What if the contamination includes a smudge?

The filter is a high-quality, coated optical component and should be treated with extreme care. Scratches, chemical contamination, or other damage due to improper cleaning may void the warranty.

- Remove the camera from the optical assembly and bring the camera to a clean, dry location where it is safe to use flammable solvents (please see caution below)
- Carefully loosen the lens mount lock ring using the supplied DVC lock ring wrench.
- Orient the camera so that the lens mount is pointing downward and carefully unscrew the lens mounting ring and integral filter.
- Place the camera face down on a clean, dry surface to prevent particles from accumulating on the CCD faceplate.
- Once the filter is removed, Use a CLEAN, DRY (preferably brand-new), camel hair lens cleaning brush (such as those used by photographers) to gently wipe the particles off of the filter.
- Re-examine the filter after removing the dust. If a smudge is still visible, proceed by dipping a clean, lint-free cotton swab in ethyl or isopropyl alcohol. The swab should be saturated, but not dripping.
- Carefully draw the swab once across the surface, then rotate the swab 180 degrees to expose the fresh surface and draw it across the filter surface again. Be careful not to pool alcohol on the glass surface.
- Re-examine once again and repeat the process once, if necessary.

If contamination continues to be a problem, please call DVC Customer Service for assistance.

Caution: ethyl and isopropyl alcohols are highly flammable! Do not use near extreme heat, arcing electrical equipment (such as space heaters) or open flame! Use only with proper ventilation. Follow all safety instructions provided by the manufacturer of the alcohol product.

7.1.4. Infra-red filter removal and installation

If greater near-infra-red sensitivity is desired, the infra-red filter can be removed. It is important to note that removal of the IR filter can allow debris to collect on the CCD faceplate. Please use every precaution to avoid contact with the CCD faceplate and to keep the camera securely mounted to the optical system or capped when not in use.

7.1.5. How to remove the IR filter

Caution: This procedure will cause the focus calibration to be lost. Readjustment of the lens back-focus will be required after reassembly

Loosen the lens mount lock ring with the wrench supplied by DVC

Unscrew the lens mount/filter assembly ring from the camera body and remove the lock ring from the lens mount ring

Hold the lens cap with the pins sticking upward in one hand

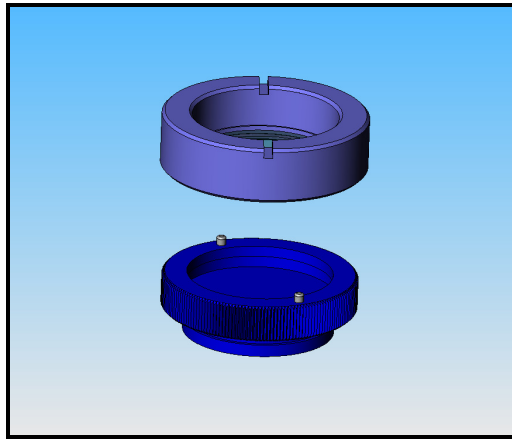

Lower the lens filter assembly on to the pins with the other hand

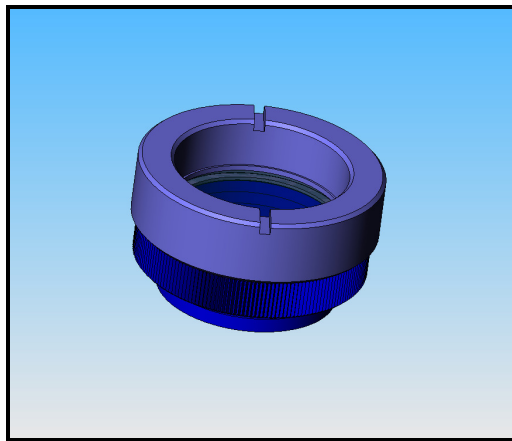

Hold the lens cap and rotate the lens ring anti-clockwise and then remove the lens ring.

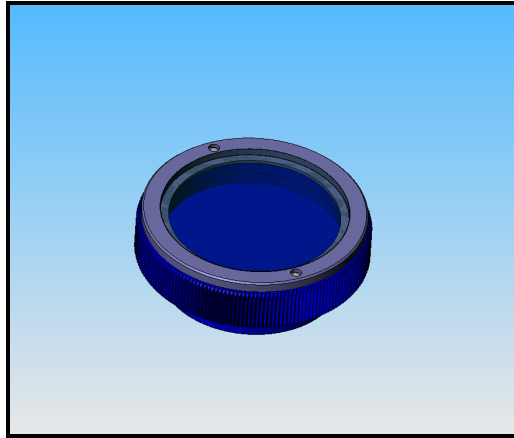

Remove the filter from the filter ring with lens tissue and store in a protective container

Replace the lens ring on to the filter ring and screw on clockwise

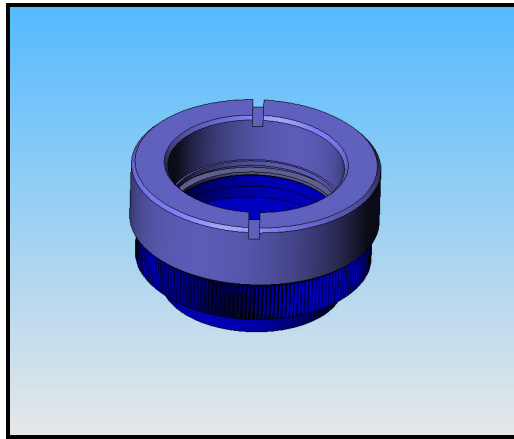

Remove the lens ring from the lens cap

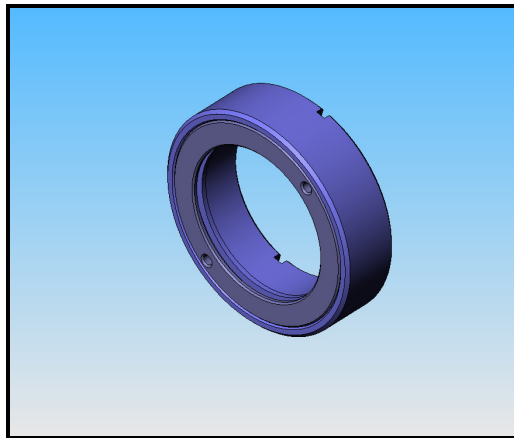

Screw the lock ring back onto the lens mount ring and screw both back onto the camera. Adjust focus by loosening the lock ring and rotating the lens mount ring to adjust the lens-to-CCD distance.

To re-install the IR filter or other filters, reverse the above procedure.

7.1.6. Cleaning the CCD faceplate

The CCD faceplate is a delicate optical surface and should not be exposed unless absolutely necessary. It will be exposed if the infra-red filter is removed.

Never attempt to clean the CCD faceplate unless the dirt or debris is a noticeable problem in the image and cleaning the lens does not remedy the problem. Any time the CCD sensor is exposed, it is at risk of being damaged. Use common sense, and carefully follow these guidelines.

7.1.6.1. What must I do before cleaning the CCD imager faceplate?

First, carefully examine the CCD faceplate in a clean location under a strong, direct light. Try to determine if the contaminants are a few dust particles, an oily smudge (such as a fingerprint) or both.

7.1.6.2. What if the contamination is only a few dust particles?

If you are sure that the contamination is particulates:

- Use a CLEAN, DRY (preferably brand-new), camel-hair lens cleaning brush (such as those used by photographers) to gently wipe the contaminants off of the CCD Faceplate.
- **If in doubt, or if the CCD faceplate surface is very dusty, please call DVC customer service before proceeding.**
-

7.1.6.3. What if the contamination includes a smudge?

DVC strongly recommends returning the camera to the factory for professional cleaning to avoid damaging the CCD faceplate. *Scratches, chemical contamination, or other damage due to improper cleaning may void the camera warranty.*

- Remove the camera from the optical assembly and bring the camera to a clean, dry location where it is safe to use flammable solvents (please see caution below).
- Carefully loosen the lens mount lock ring using the supplied DVC lock ring wrench.
- Orient the camera so that the lens mount is pointing downward and carefully unscrew the lens mounting ring.
- Place the camera face down on a clean, dry surface to prevent particles from accumulating on the CCD faceplate.
- Use a CLEAN, DRY (preferably brand-new), camel-hair lens cleaning brush (such as those used by photographers) to gently wipe the particles off of the CCD faceplate.

-
- Re-examine the CCD faceplate after removing the dust. If a smudge is still visible, proceed by dipping a clean, lint-free cotton swab in ethyl or isopropyl alcohol. The swab should be saturated, but not dripping.
 - Carefully draw the swab once across the CCD faceplate surface, then rotate the swab 180 degrees to expose the fresh surface and draw it across the filter surface again. Be careful not to pool alcohol on the glass surface.
 - Re-examine once again and repeat the process once, if necessary.

If contamination continues to be a problem, please call DVC Customer Service for assistance.

Caution: Ethyl and isopropyl alcohols are highly flammable! Do not use near extreme heat, arcing electrical equipment (such as space heaters) or open flame! Use only with proper ventilation. Follow all safety instructions provided by the manufacturer of the alcohol product.

8. Warranty and After-Sale Service

DVC Company warrants equipment manufactured to be free from defects of material and workmanship. Any part or parts will be repaired or replaced when proven by DVC examination to have been defective within two years from the date of shipment to the original purchaser. Any warranty repairs will be performed at the factory or as otherwise authorized by DVC, in writing. Transportation charges to DVC shall be pre-paid by purchaser.

This warranty does not extend to DVC manufactured equipment subjected to misuse, accident, neglect or improper application. Nor does the warranty extend to DVC manufactured equipment that is repaired or altered by anyone other than DVC or those authorized by DVC, in writing. Products manufactured by other companies, but re-sold by DVC such as lenses, optical and electro-optical assemblies, power supplies, cables, image processor boards and software are warranted by the original manufacturer.

This warranty is in lieu of all other warranties expressed or implied. DVC shall not be liable for any collateral or consequential damages.

A Return Material Authorization (RMA) Number must be obtained from DVC prior to returning any item for warranty repair or replacement.

9. Copyright Information

Copyright © 2004 DVC Company. All rights reserved.

Copyright on this document is owned by DVC Company, 10200 Highway 290 West, Austin, Texas 78736

The information contained in this document is proprietary to DVC Company. Information in this document may be used for non-commercial, personal and educational information purposes only, and may be viewed, copied, printed and distributed only in accordance with these terms and conditions of use. This information may not be copied nor duplicated in any form, in whole or in part, for use for profit or another business. All printouts, copies or reproductions of all or any part of the information contained in this document must include all patent, copyright and/or trademark notices originally included with the information. User obtains no rights in the information or in any product, process, technology or

trademark which it includes or describes, and is expressly prohibited from modifying the information or creating derivative works without the express written consent of DVC Company. DVC models represented in photographs may differ slightly from products shipped due to continuing product improvements and variations. DVC reserves the right to make changes to product specifications and documentation at any time without notice. The information in, or references from, this document are believed to be accurate and reliable, however, no responsibility is assumed by DVC for its use. DVC reserves the right to change, modify or correct the information contained in this document at any time without notice. While DVC has used all reasonable efforts to indicate and to supply information regarding trademarks used in this publication, the absence of a trademark identifier is not a representation that a particular mark is not a trademark. All non-DVC products, brand names, company names are trademarks or registered trademarks of their respective owners, and appear in this document for reference only.

Disclaimer: The information in this document is provided "as is." DVC expressly disclaims all representations and warranties of any kind regarding the contents or use of the information including, but not limited to, express and implied warranties of accuracy, completeness, merchantability, fitness for a particular use, or non-infringement. In no event will DVC be liable for any direct, indirect, special, incidental or consequential damages, including lost profits, lost business, or lost data, resulting from the use or reliance upon the information, whether or not DVC has been advised of the possibility of such damages.

Appendix A: Exposure Timing Diagrams

Continuous, overlapped, electronic-shuttered exposure mode

In the continuous, overlapped exposure mode, the camera remains in an idle state until the falling edge of the trigger. A first exposure is made, followed by the typical, interline CCD overlapped exposure/readout cycle. Electronic shuttering allows the exposure to be adjusted via software control without altering the frame rate of the readout.

Any further triggers while the camera is operating continuously are ignored. The camera will remain in this continuous mode until disabled through software command. It can then be re-armed for another trigger event.

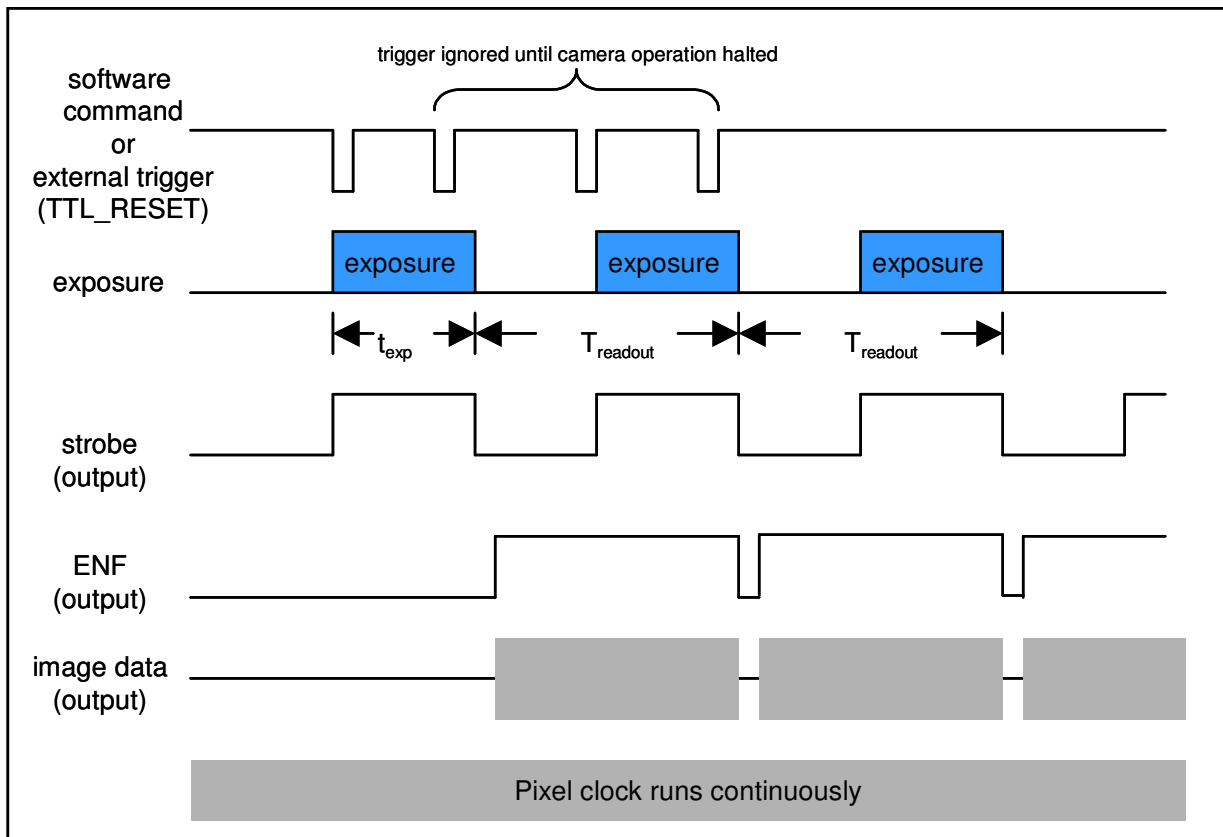

Continuous, overlapped exposure mode with electronic shutter. Strobe pulse occurs only if enabled.

Continuous, overlapped, extended-exposure mode

This mode is similar to the overlapped, electronic-shuttered exposure mode except that the electronic shutter is not enabled and the exposure times are greater than one readout cycle (frame time). As a result, readout frame rate will decrease as exposure time is increased, but the overlapping exposure and readout provide the maximum frame rate for a given exposure time. This mode also offers much longer integration times than overlapped, electronic-shuttered exposure mode.

Any further triggers while the camera is operating continuously are ignored. The camera will remain in this continuous mode until disabled through software command. It can then be re-armed for another trigger event.

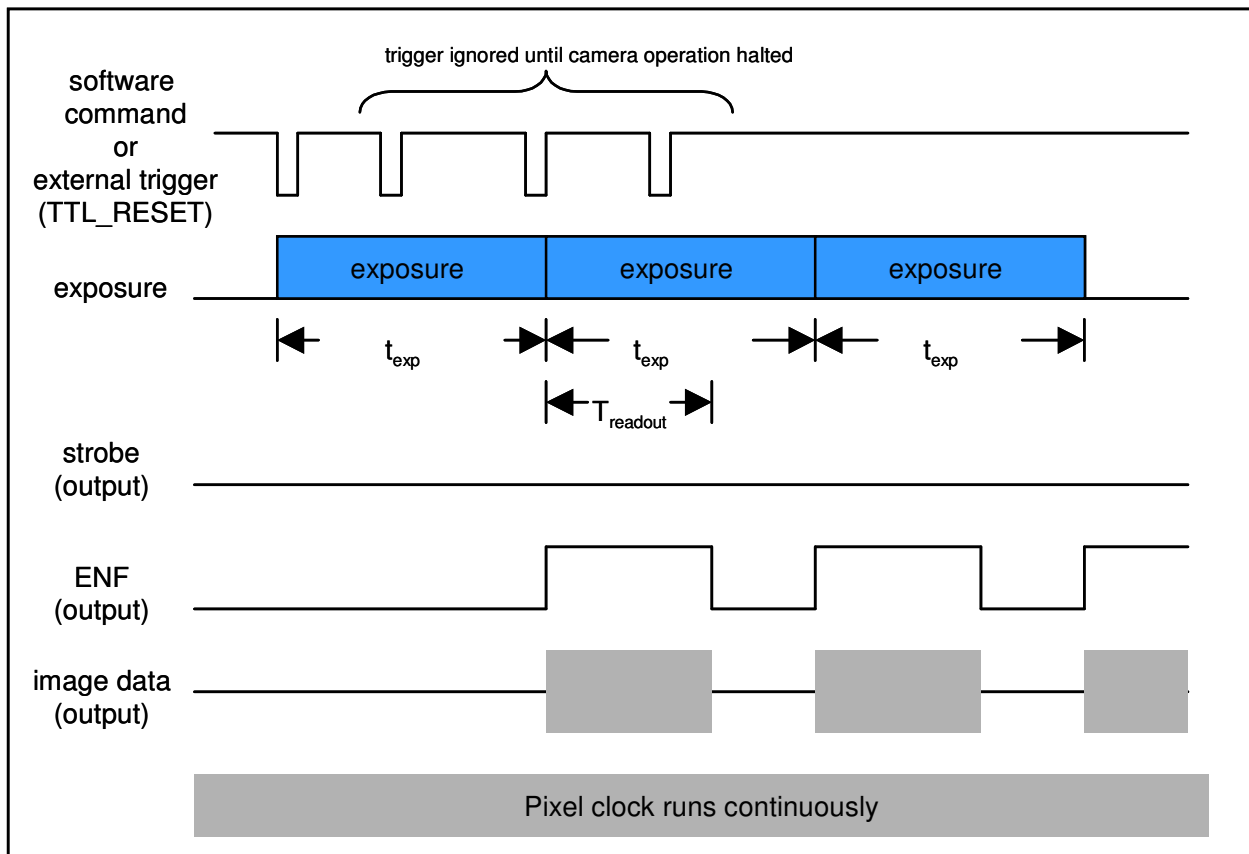

Continuous, overlapped, extended-exposure mode. Strobe pulse is disabled due to continuous nature of exposure

Continuous, non-overlapped exposure mode

This mode is similar to the overlapped exposure mode except that the exposure and readout periods are separate and do not overlap. As a result, readout frame rate will decrease as exposure time is increased. This mode also offers much longer integration times than overlapped exposure mode, and exposures are controlled via software. Any further triggers while the camera is operating continuously are ignored. The camera will remain in this continuous mode until disabled through software command. It can then be re-armed for another trigger event.

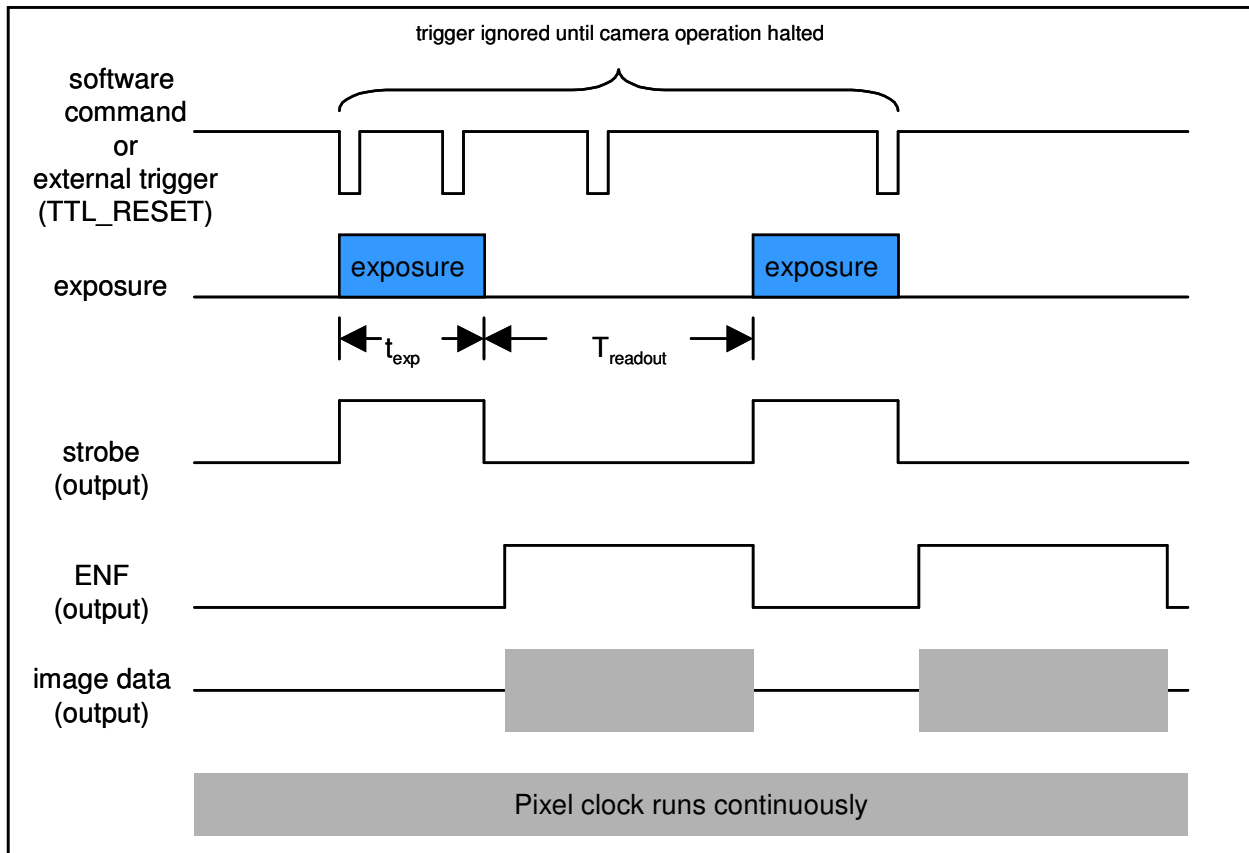

Continuous, non-overlapped exposure mode. Strobe pulse occurs only if enabled.

Edge-triggered exposure (single frame capture) mode

Edge-triggered exposure mode operates almost identically to the first frame of the non-overlapped continuous mode except that instead of continuing to run, the camera returns to the armed state, waiting for another trigger. Exposure is controlled by software.

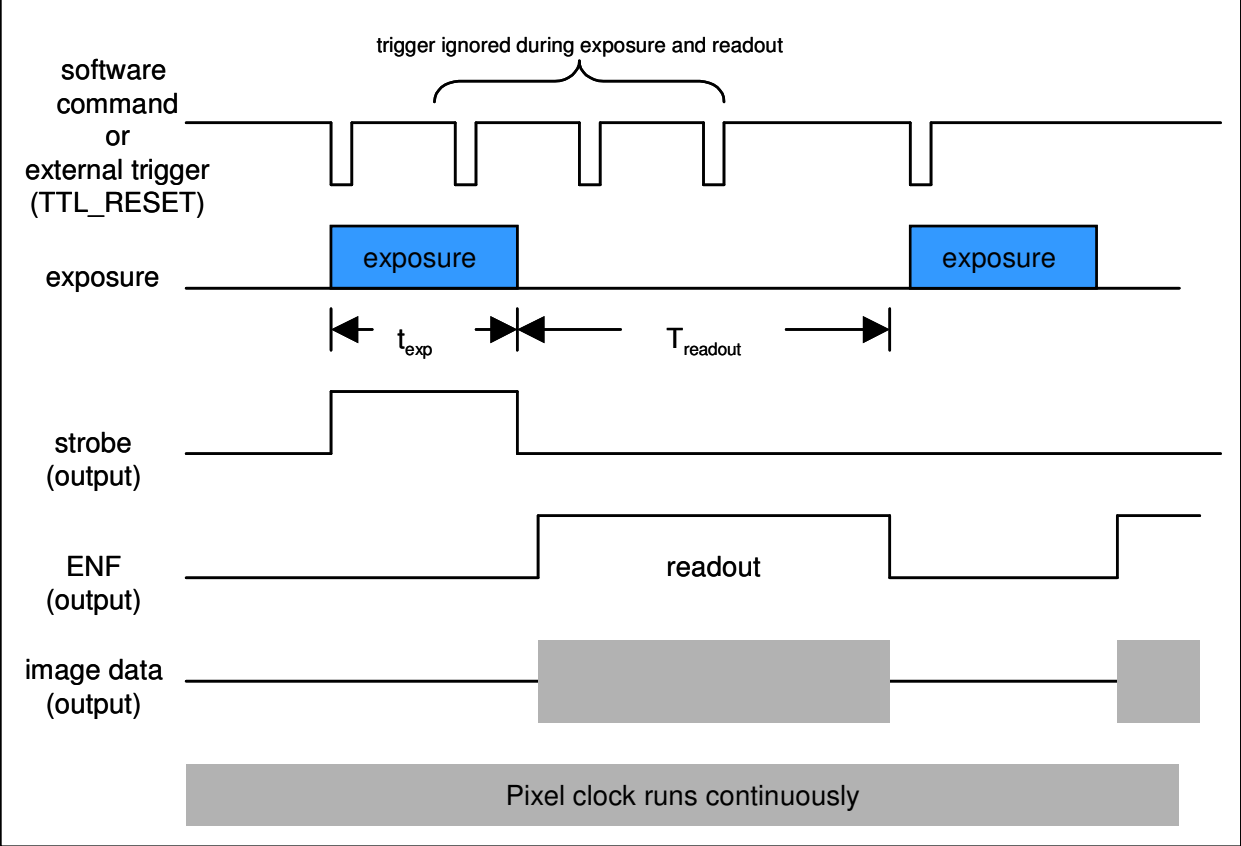

Edge-triggered exposure mode. Strobe pulse occurs only if enabled.

Bulb (pulse-width exposure) mode

Bulb mode allows the camera exposure to be controlled by the external trigger signal. The leading edge of the trigger signal initiates the exposure, and the camera will continue to expose until the trailing edge of the trigger, as shown. The readout sequence begins immediately after the trigger signal trailing edge, and at the end of readout, the camera returns to the armed state, awaiting the next trigger. Any trigger activity during the readout sequence is ignored.

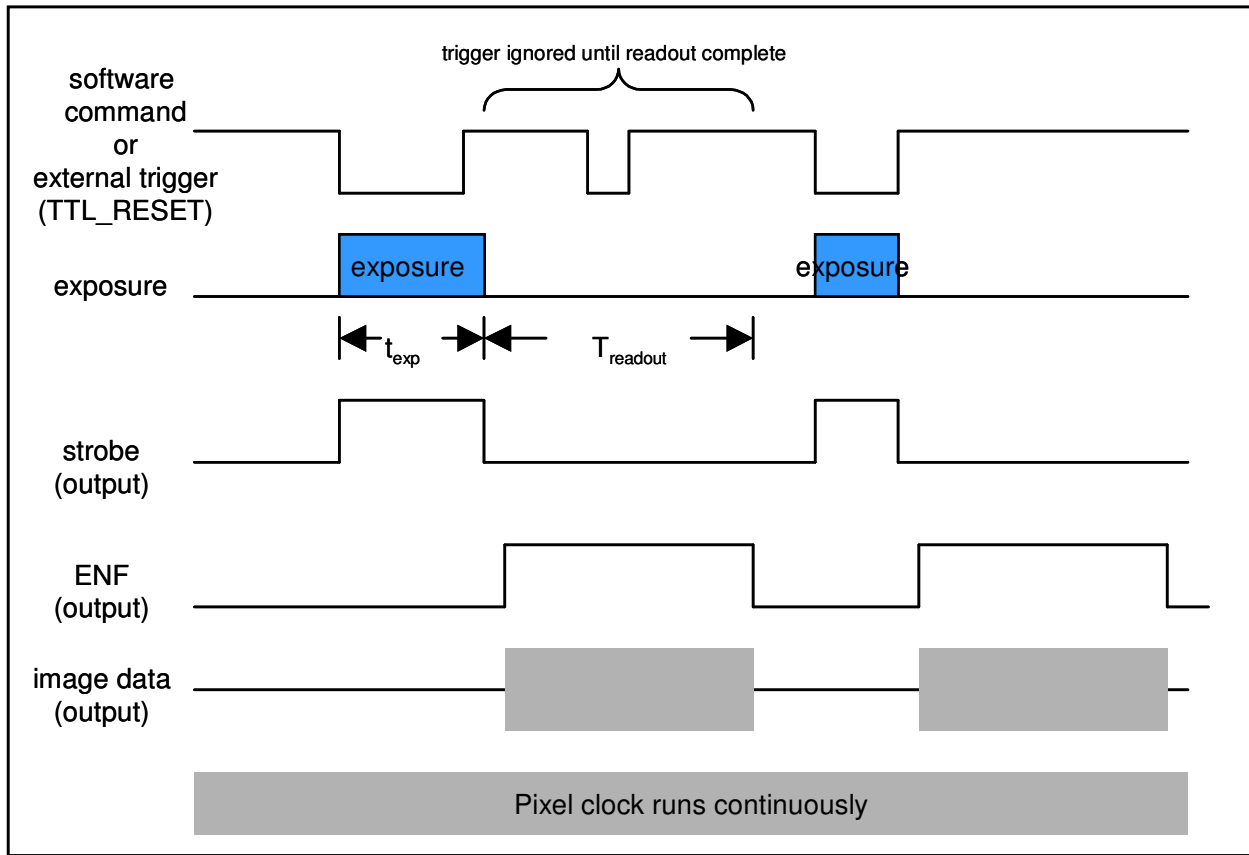

Bulb (pulse-width exposure) mode. Strobe pulse occurs only if enabled.

Appendix B: description of DVC-340 auxiliary and power supply connectors

Auxiliary connector

The auxiliary connector on the DVC-340 camera allows the user access certain camera control and internal status signals. The following section describes each signal.

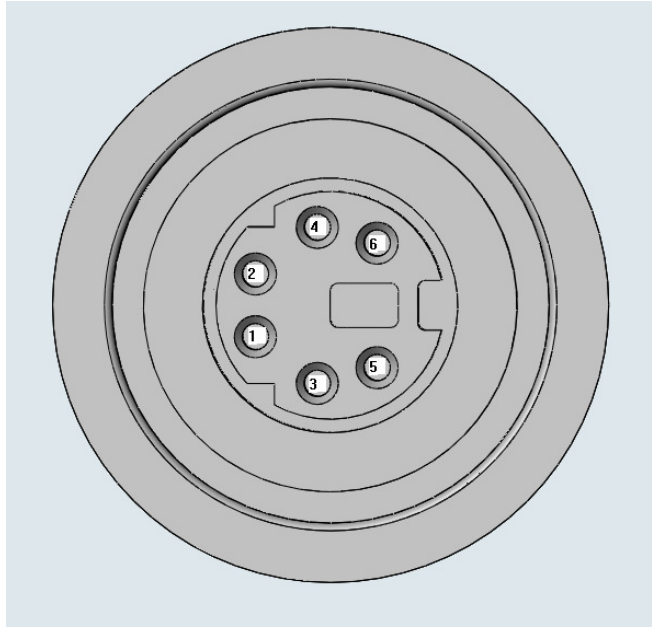

Illustration of the auxiliary connector on the rear of the DVC-340 camera

Auxiliary Connector Pin Signal list:

Pin #	Signal
1	ENL (Output)
2	DIFF_RESET_OUT (Output)
3	TTL_RESET (Input)
4	GND
5	ENF (Output)
6	STROBE/INT-PULSE (Output)

Pin 1, ENL

ENL refers to “Enable Line.” It is an active-high TTL signal and is asserted during the valid pixel period on each line, as shown in the diagrams in Appendix A. It returns low during the inter-line period between each line and during the inter-frame period between each frame.

Pin 2, DIFF_RESET_OUT

This pin is an active-low TTL signal that is the buffered version of the CameraLink CC1 signal. The CC1 signal, driven from the host, is one of the software-controlled trigger signals for the camera as described in Appendix A. The CC1 signal is brought out of the

camera as DIFF_RESET_OUT to allow users to trigger other devices. DIFF_RESET_OUT is labeled INPUT_1 on older DVC cameras and on the Mini-DIN-to-BNC cable accessory sold by DVC.

Pin 3, TTL_RESET

TTL_RESET is a TTL input used to trigger exposures. It functions identically to the CameraLink CC1 signal. TTL_RESET is also labeled VRST_INT on older DVC cameras and on the Mini-DIN-to-BNC cable accessory sold by DVC.

Pin 4, GND

This is the electrical ground for the camera.

Pin 5, ENF

ENF refers to Enable Frame and is a TTL output that is high during active readout lines. EN_FRAME remains high throughout the active readout and returns low between frames.

Pin 6, STROBE (and programmable output)

STROBE is a TTL output that, if enabled, is high during the actual sensor exposure time in certain modes. Refer to the diagrams in Appendix A for details on STROBE operation with respect to the exposure interval in each mode. STROBE is typically used to synchronize an external flash lamp or other device with the camera.. The STROBE signal can also be configured as a programmable output that can be set high or low from the host computer. Refer to the DVC API documentation for details.

Power supply connector pin assignments

The power supply connector is a standard, DB-9 male connector with the following pin assignments:

Pin No.	Signal Name	Signal Name	Pin No.
6	GND	+5 VDC, 250mA	1
7	Reserved	+4.8VDC, 1250mA	2
8	GND	-15 VDC, 250mA	3
9	Reserved	Reserved	4
		+15 VDC, 250mA	5

Appendix C: Specifications

CCD

KAI-0340 progressive scan interline CCD

Active Pixels	640 X 480
Pixel Size	7.4 μm X 7.4 μm
Imager Size	5.92 mm (diagonal)
Aspect Ratio	4:3
Peak QE	>55%
Full Well	38,000e- @ 20 MHz 20,000e- @ 40 MHz

340M

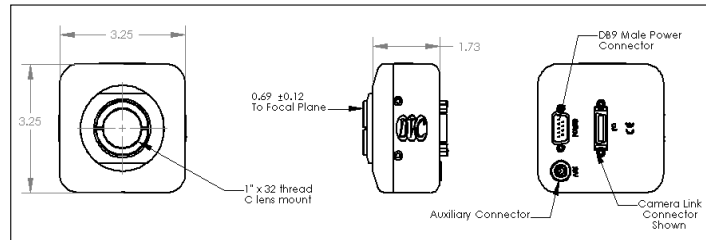

Digital Video

I/O	12 Bit Camera Link		
A/D Converter 1	20 MHz @ 12 bits		
A/D Converter 2	40 MHz @ 12 bits		
Read Noise	12e- @ 20 MHz		
ROI (selected examples)		20MHz	40MHz
	240x240	109	209
	120x120	206	382
Binning (selected examples)		20MHz	40MHz
	1X1 640x480	55	109
	1X2 640x240	109	206
	2X2 320x240	109	206
	3X3 213x160	160	305
	4X4 160x120	205	374

Linear Power Supply

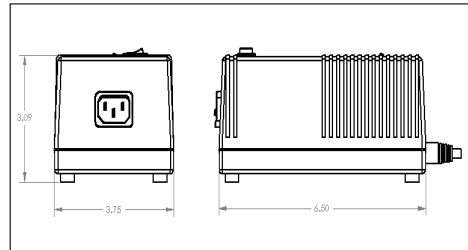

CCD Quantum Efficiency

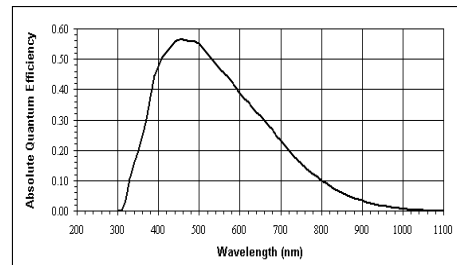

Electrical

Input Voltage	110/220 VAC 50/60 Hz
Power	<5 Watts

Mechanical

Size	3.25" (H) X 3.25" (W) X 1.73" (L)
Weight	18 ozs. (505 grams)
Lens Mount	C-mount
Camera Mount	1/4" X 20 Standard Tripod mount
Camera Connector	Camera Link....MDR-26
Power Connector	DB-9M

DVCView™ Interface Software module, standard

Camera Control

Gain Control Range	35 dB
Offset Control (black)	0% to 6% in 256 steps
Exposure Range	50 μs to 1 hour

IR Filter Response

